

INTRODUCTION

If you can undertake the basic work yourself, you save money and the inconvenience of waiting for a plumber.

Basic plumbing repair needn't be a daunting task, all you need to get started are a few essential tools, a working knowledge of your system and an ability to identify problems.

SKILL LEVEL ●●●●●

The simple skills required for basic plumbing are explained in this project.

It helps to have some metalworking experience.

SAFETY FIRST

Take care when working with a blowtorch in loft spaces. Be aware that pipes take time to cool after exposure to the blowtorch flame.

TO COMPLETE THIS PROJECT YOU WILL NEED...

- Adjustable Spanners
- Files
- Gate Valves
- Hacksaw
- Hose
- Hose Clips
- Isolator Valves
- Open-Ended Spanners
- Pipe Insulation
- Pvc Tape
- Repair Putty
- Screwdriver
- Spare Washers
- Timber (wooden batten)
- Tube Cutter
- Wire Wool
- Capillary Joints
- Compression Joints
- Heatproof Mat
- Slip Coupling

HOW TO: BASIC PLUMBING

1 - PREPARATION

STEP 1: Familiarise yourself with the layout of your plumbing - this will enable you to identify the cause of a problem and shut off the water for servicing.

STEP 2: Locate the stopcock on the rising main - the pipe that brings fresh water into your home. The stopcock controls the flow of water and is used to shut off the entire supply in an emergency. The stopcock may be found under the kitchen sink, beneath the stairs or in the cellar or basement.

STEP 3: Check if there are isolating valves on the low pressure pipes to taps, toilet cisterns and household appliances - these valves enable servicing to be carried out without turning off the mains. They are usually located next to the storage cistern in the loft.

Make up a kit of basic plumbing tools and a set of spare washers to fit the taps and valves around the house.

Keep your plumber's phone number handy in case you are faced with a serious problem.

2 - DRAINING THE SYSTEM

In order to repair a leak, run new pipes or service a toilet cistern, it is necessary to be able to drain various parts of the system.

Water is supplied to a house under relatively high mains pressure. In most houses it is directed via the rising main pipe to a cold water storage cistern in the loft. A pipe connected to the rising main feeds drinking water directly to the kitchen sink. All other taps and fittings, including the hot water storage cylinder, are supplied indirectly by a low pressure gravity-fed system from the storage cistern.

TO DRAIN THE COLD WATER KITCHEN TAP AND PIPE:

Close the stopcock on the rising main
Open the tap to empty the short length of pipe.

TO DRAIN COLD WATER TAPS IN THE BATHROOM/TO DRAIN THE CISTERN:

Shut off the cold feed valve from the storage cistern in the loft.
Run the bathroom taps.

or:

If there is no isolating valve, shut off the supply of water to the cistern by tying the arm of the float valve to a batten placed across the top. Run the taps to drain the cistern. Use this method if you ever need to work on the cistern itself.

TO DRAIN A TOILET CISTERN:

Tie up the float-valve arm.
Flush the toilet.

If you need to work on the supply pipe to the cistern, shut off the water supply from the storage cistern in the loft (see above).

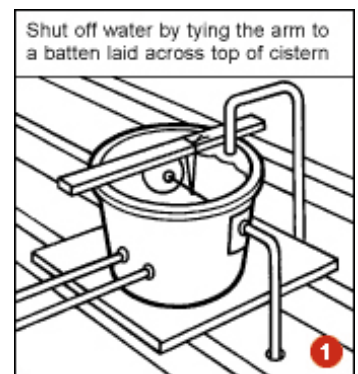

HOW TO: BASIC PLUMBING

TO DRAIN HOT WATER TAPS:

Turn off the immersion heater and the central heating boiler.
Shut off the supply of water from the storage cistern in the loft to the hot water cylinder.
Run off the water from the hot taps.

TO DRAIN THE HOT WATER CYLINDER:

Attach a hose to the draincock at the base of the cylinder. If the cylinder contains a heat exchanger fed from the boiler, this can only be emptied through the boiler draincock.

3 - FITTING EXTRA VALVES

To save time and water when draining pipes for minor repairs and servicing, install extra valves to divide the system into sections or to isolate individual fittings and appliances.

STEP 1: Fit gate valves on the cold feed pipes from the storage cistern **2**.
This will save you having to drain the stored water when servicing the low pressure side of the system. If you fit a second stopcock on the in-feed pipe, you can drain the cistern without turning off the rising main.

STEP 2: Fit isolator valves in the supply pipes to taps and appliances. This will enable you to isolate the individual fitting for servicing **3**.

4 - FILLING THE SYSTEM

STEP 1: First close all taps and drainage points, then open the main stopcock. Check that the float valves operate properly as the water levels rise in the storage cisterns. If water pours from a cistern overflow, the valve may have stuck open. Work the float arm up and down a few times to free the valve.

STEP 2: When the system is full, open the taps. Water is likely to splutter out at first as trapped air is released.

STEP 3: If water fails to flow or only trickles out, there may be an airlock. Connect a length of garden hose to the high pressure kitchen tap at one end and the airlocked tap at the other **4**.

Opening both taps allows the high pressure water to push trapped air out of the pipe. Turn off the taps, disconnect the hose and test the airlocked tap again. Repeat if necessary allowing more time for the air to clear. Should the air lock not clear, try again by entering the system. If no success, call a plumber.

5 - CUTTING & JOINING PIPES

Most homes are plumbed with 15mm, 22mm and sometimes 28mm diameter copper pipe. Joining pipework is basic to all plumbing installations and many repairs.

Copper pipes can be joined with brass compression fittings or soldered capillary joints. You can cut copper pipe with a fine toothed hacksaw, but it is easier and more accurate if you use a tube cutter.

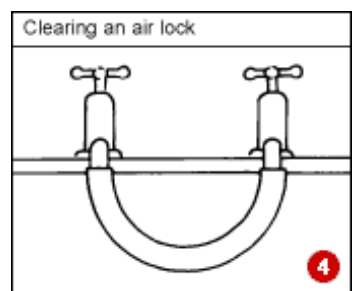
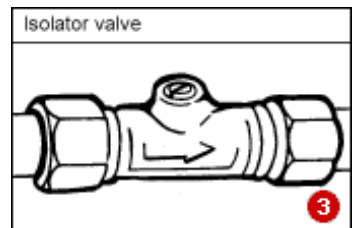
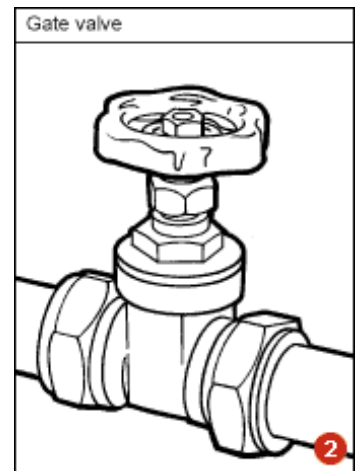

HOW TO: BASIC PLUMBING

Whatever type of fitting you use, the pipe must first be cut perfectly square.

To cut a pipe, lightly clamp the cutter on the pipe, with the cutting wheel on the cut line. Rotate the cutter around the pipe, tightening it a little after each revolution, until the pipe is severed **5**.

Remove burrs from inside the cut end, using the pointed reamer on the cutting tool or use a small half-round file.

TO JOIN COPPER PIPES WITH A COMPRESSION FITTING:

STEP 1: First remove the cap nut and slide it over the end of the pipe.

STEP 2: Slip the brass ring, known as an olive, onto the pipe.

STEP 3: Push the pipe into the body of the fitting, slide the olive up to the fitting and tighten the nut by hand.

STEP 5: Tighten the nut fully with a pair of spanners, one to hold the body of the fitting, and the other the nut. Assemble the other half of the fitting in the same way.

FOR SOLDERED JOINTS, USE PRE-SOLDERED FITTINGS AS THESE ARE EASIER TO WORK WITH:

STEP 1: Clean the cut ends of the pipes and the inside of the fitting to a bright finish, using wire wool.

STEP 2: Apply a paste flux to the fitting and pipes, then push the parts together.

STEP 3: Using a heatproof mat as a shield behind the fitting, evenly heat the joint with the flame of a gas blowtorch until a rim of shiny solder appears around the ends of the fitting **6**.

STEP 4: Remove the heat and leave the metal to cool.

6 - MENDING DAMAGED PIPES

If you accidentally drive a nail through a copper pipe under the floor, you may not even notice for a while. The only indication is a faint hissing until, eventually, a damp patch appears on the ceiling in the room below.

If your floors are to be carpeted or covered with sheet vinyl, paint the lines of hidden plumbing across the floorboards to avoid nailing into pipes in the future.

STEP 1: Identify the system which is supplying the pipe.

Water is supplied to a house under relatively high mains pressure. In most houses it is directed via the rising main pipe to a cold water storage cistern in the loft. A pipe connected to the rising main feeds drinking water directly to the kitchen sink. All other taps and fittings, including the hot water storage cylinder, are supplied indirectly by a low pressure gravity-fed system from the storage cistern.

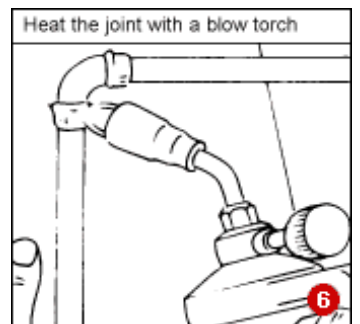
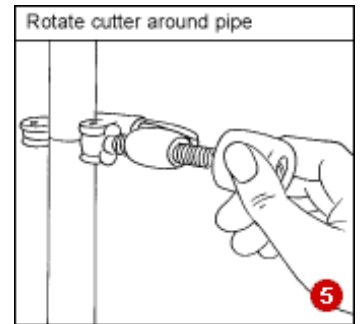

HOW TO: BASIC PLUMBING

STEP 2: Drain the system and uncover the pipe. See "Draining the system"

STEP 3: Cut out the damaged section with either a fine toothed hacksaw or a tube cutter, if you have one to hand. See "Cutting & joining pipes "

STEP 4: Fit a straight compression joint in the pipe run **7** .

To join copper pipes with a compression fitting, first remove the cap nut and slide it over the end of the pipe. Then slip the brass ring, known as an olive, onto the pipe.

Push the pipe into the body of the fitting, slide the olive up to the fitting and hand tighten the nut. Now tighten the nut fully with a pair of spanners, one to hold the body of the fitting, and the other the nut. Assemble the other half of the fitting in the same way.

- If you cannot move the pipe sufficiently to fit a conventional fitting, use a slip coupling that can be slid along the pipe.
- In an emergency, seal a punctured pipe temporarily with a short length of garden hose slit lengthwise and held in place with hose clips **8** .

You can also make a serviceable repair using an epoxy putty repair kit:

- Clean the metal locally with wire wool.
- Mix the two-part putty, following the manufacturer's instructions, and press it into the hole.
- Build up the putty to form a collar around the pipe, about 6mm (1/4in) thick and 50mm (2in) on either side of the hole.
- Smooth the putty with a damp soapy cloth **9** .

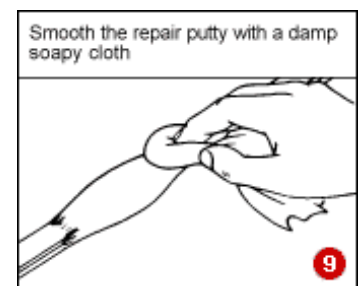
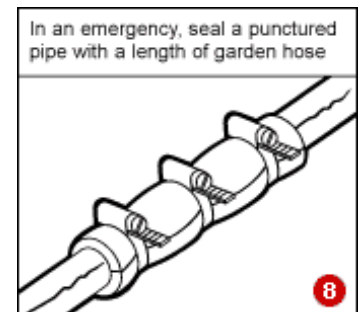
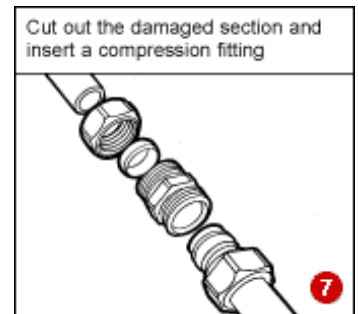

7 - THAWING FROZEN PIPES

Uninsulated pipes exposed to freezing temperatures are likely to become blocked with ice. This commonly occurs in cold uninsulated lofts. Garden taps are also prone to freezing. You may not be aware of the problem until the water refuses to flow when you turn on a tap.

Old plumbing, especially the rising main, is invariably made from lead which, being a soft metal, has a tendency to split as the water freezes - call in a qualified plumber to deal with permanent repairs to lead pipework.

STEP 1: Trace the location of the blockage by following the run of frozen pipework.

STEP 2: Because copper is a good conductor of heat, you can usually thaw a pipe, using an electric hair dryer. Warm the pipe gradually, working back from the affected tap or valve. Treat old lead pipe in the same way, but warm the whole pipe evenly. If you cannot use a hairdryer, wrap the frozen pipe in hot towels.

HOW TO: BASIC PLUMBING

STEP 3: Insulate vulnerable plumbing to prevent it freezing again. You can buy lagging bandage to wrap around the pipework, but the job is much easier using foamed plastic tubes split lengthwise to fit over standard size pipes.

When insulating long straight runs, butt the ends of the tubes together and bind them with self-adhesive PVC tape. Cut a tube with a sharp knife to fill any gaps.

At a bend, cut a series of wedges from the split edge to allow the tube to be formed around the curve. Use tape to bind and seal the tube in place.

At a right angle elbow joint, mitre the ends of two adjoining foam tubes.

When two pipes meet at a tee-junction, cut a wedge from the side of the straight tube to receive the tapered end of the tube joining it **10**.

