

## HOW TO: PLUMBING CARE AND REPAIR

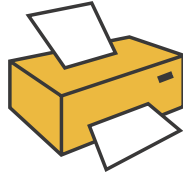

Click here to  
**PRINT THIS  
HOW TO**

### INTRODUCTION

Undertaking simple plumbing repairs as they occur avoids the risk of more expensive work later.

It makes sense to repair leaking taps and overflows as soon as possible. They are not only wasting a valuable resource, but leaks have a tendency to get worse, causing all manner of problems associated with damp. The methods described here cover the most common fittings and appliances used in the average home. If you find your situation is different, get the advice of a plumber before you start work, and always remember to turn off the water supply before making repairs!

See the B&Q leaflet 'Basic Plumbing' for instructions on shutting off your water supply and draining the system.

### SKILL LEVEL ●●●

No special skills are required for any of the repairs described in this section.

● First Time Project   ●● Novice DIY'er   ●●● Basic DIY Skills Required   ●●●● Practised DIY'er   ●●●●● Experienced DIY'er

### SAFETY FIRST

Plumbing repairs are seldom dangerous unless leaking water is soaking areas where there are electrical cables or fittings. Switch off the power at the consumer unit and call a plumber.

## TO COMPLETE THIS PROJECT YOU WILL NEED...

- Adjustable Wrenches
- Bucket
- Chemical Drain Cleaner
- Drain/WC Unblocker (Auger)
- Engineer's Pliers
- O-Rings
- Penetrating Oil/WD40
- Penknife
- Petroleum Jelly
- Plumber's Hemp
- Reseating Tool
- Sink Plunger/Hydraulic Pump
- Slip-Joint Pliers
- Syphon Washer
- Washers & Diaphragms
- Wire Wool

# HOW TO: PLUMBING CARE AND REPAIR

## 1 – CLEARING WASTEPIPES

Water draining slowly from a sink, bath or basin is a sure sign that a serious blockage is imminent. Leave the water to drain, then pour a chemical cleaner down the waste outlet to dissolve the obstruction before it becomes a major problem. Flush out the waste system with clean water.

If a chemical cleaner fails to clear the blockage, try using a sink plunger. Ensure there is enough water in the sink to cover the rubber cup of the plunger. Block the overflow outlet at the back of the sink or basin with a wet cloth. Place the plunger over the waste outlet and pump the plunger up and down to create pressure in the pipework.

Alternatively, use a hand-operated hydraulic pump. Fill the pump with water and place it over the waste outlet. Push down on the handle to force a jet of water through the wastepipe.

If you cannot shift the obstruction with pressure, you will have to dismantle the waste system. Sinks and basins are fitted with water-sealed traps, designed to prevent drain odours entering the house. Check the trap for a blockage.

A bottle trap is designed with a large access cap. Place a bucket under the trap and unscrew the cap. Wash out the trap then refit the cap.

To clean a trap that forms a U-bend, you will have to remove the complete unit unless it is fitted with a cleaning eye sealed with an access cap.

Access may be provided for clearing blockages in the wastepipe beyond the trap. If not, remove the trap and pass a hooked wire into the pipe to free the blockage. Alternatively, buy a flexible drain auger.

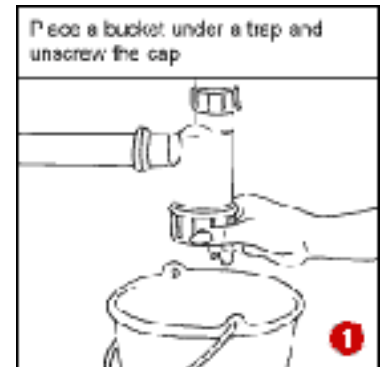

## 2 – LEAKING TAPS – REPLACING WASHERS

A tap that continues to drip requires rewashing. You will have to remove the headgear mechanism to replace it. However, when water is leaking from the tap spindle, just below the head, it is a sign that the gland packing has failed, if this is the case see 'Replacing gland packing'.

### Step 1

Turn off the water supply.

### Step 2

For a traditional capstan-head pillar tap, first remove the cross head by releasing its retaining screw. Next, unscrew the bulbous shroud below the head to expose the tap mechanism.

On modern taps, the head and shroud are one-piece mouldings. Simply pull off the push-fit types or remove the fixing screw hidden beneath the coloured hot or cold identification disc. Use a thin blade to pry out the disc.

### Step 3

Just above the tap body is the headgear nut. Holding the tap firmly, unscrew the nut and lift the headgear assembly out of the tap body.

### Step 4

You will find the worn washer at the base of the assembly attached to the 'jumper'. With some taps, the washer fits over a stud in the centre of the jumper, and is simply prised off and replaced. Other washers are held in place with a retaining nut.

Bath-tap washers are larger than those required for sink and basin taps - replace a worn washer with a new one of the correct size.

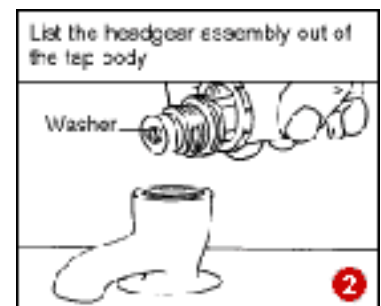

### Step 5

Before you replace the headgear assembly, check the condition of the seat inside the tap body. The washer is compressed against the seat, and if the metal is pitted, a new tap washer may not prevent the tap leaking.

### Step 6

Buy a reseating tool to smooth the seat. Fit the tool in the tap body and adjust the cutter until it begins to remove the pitted metal as you turn the handle.

Alternatively, fit a new plastic seat over the old one. These are supplied as a kit, complete with new jumper and washer.

The latest type of taps use ceramic discs in place of traditional rubber washers. These hard-wearing units last longer, but in the event of a leak, it is necessary to replace the whole disc cartridge.

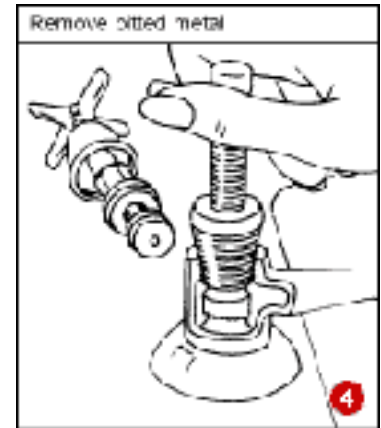

## 3 – LEAKING TAPS – REPLACING GLAND PACKING

When water is leaking from the tap spindle, just below the head, it is a sign that the gland packing has failed.

- On older taps, the rotating spindle is sealed with a waterproof packing that is compressed by a gland nut fitted to the top of the headgear assembly.
- Modern taps use rubber O-rings to form the seal.

Step 1: Turn off the water supply.

Step 2: Remove the tap head and try tightening the gland nut. Take care not to overtighten the nut as this will prevent the spindle turning.

Step 3: If the spindle continues to leak, unscrew the gland nut and pick out the old packing with a penknife. Replace it with plumber's fibre twine wound clockwise around the spindle. Grease the twine first with petroleum jelly. Pack it down and retighten the gland nut.

For taps fitted with O-ring seals, remove the headgear assembly and pull the old seals from their grooves. Replace them with new rings of appropriate size. Smear new O-rings with petroleum jelly to ensure they slide easily into place.



## 4 – STOPCOCKS AND GATE VALVES

Stopcocks are valves that control the flow of incoming water through the rising main. Due to the build-up of deposits, the spindle can become hard to turn. Since a stopcock is used to shut off the water during an emergency, it pays to open and close the valve occasionally to keep it moving freely.

Gate valves control the flow of water on the low-pressure side of the storage cistern in the loft. If gate valves or stopcocks are stiff to turn, apply penetrating oil to their spindles and turn them on and off until they begin to operate freely.

If you need to replace an old stopcock, make sure you fit it with the arrow moulded on the side of the body pointing in the direction of water flow.

## 5 – DRIPPING OVERFLOW PIPES

The level of water in a storage cistern, such as the one installed in the loft or above a toilet, is controlled by a float valve. If, for some reason, the valve does not close automatically, the water level continues to rise until it is diverted to the outside via an overflow pipe.

Older-pattern float valves are made from brass and are fitted with a small rubber washer to seal the water inlet. Modern fittings are made from plastic and incorporate a large rubber diaphragm.

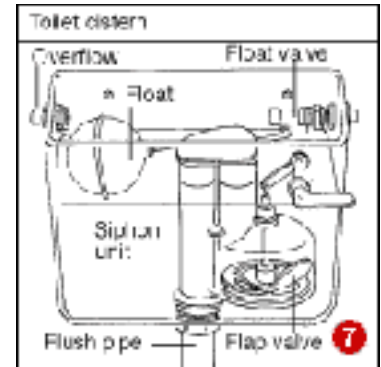

- In a hard-water area a build-up of limescale on the float arm and valve can become a problem. Chip off the limescale crust occasionally to keep the mechanism moving freely.
- If a float is punctured it will sink - as an emergency measure, tie a plastic bag around the float with an elastic band until you can replace it.
- Water will continue to seep into the cistern once the valve washer wears. To replace the valve washer follow the instructions below.

### Replacing the valve washer

#### Step 1

To replace a washer in a metal bourne valve, turn off the water supply, then pull out the split pin that connects the float arm to the valve.

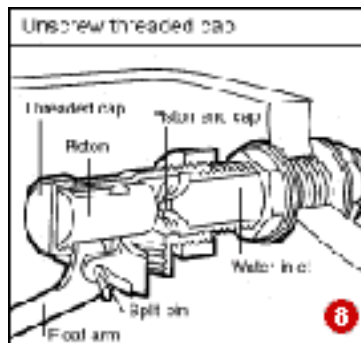

#### Step 2

Remove the arm and unscrew the threaded cap on the end of the valve body and slide out the piston.



#### Step 3

Unscrew the piston end cap that retains the rubber washer - use pliers to grip the cap while turning the piston with a screwdriver held in the side slot.



#### Step 4

Clean the parts with wire wool, then put a new washer in the end cap and refit the piston.

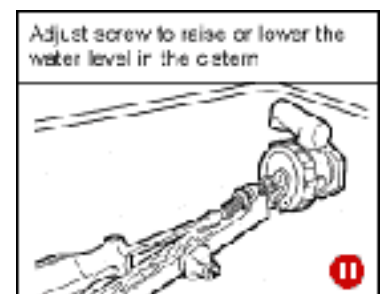

#### Step 5

Reassemble the valve, taking care to align the slot in the piston with the bottom of the valve body in order to receive the end of the float arm. Fit a new split pin.

#### Step 6

Replace the diaphragm in a plastic valve by unscrewing the large retaining cap. Pick out the old diaphragm and insert a new one.

#### Step 7

Reassemble the valve and turn the water back on. If necessary, reset the float arm with the regulator screw to raise or lower the water level in the cistern - the water should be about 25mm (1in) below the overflow.